



U4454

Uni-Door Waste Receptacle

Revision 03/11

JOB #:

ITEM #:

QUANTITY:

MOUNTING	HANDING	TYPE	SIZE	OTHER

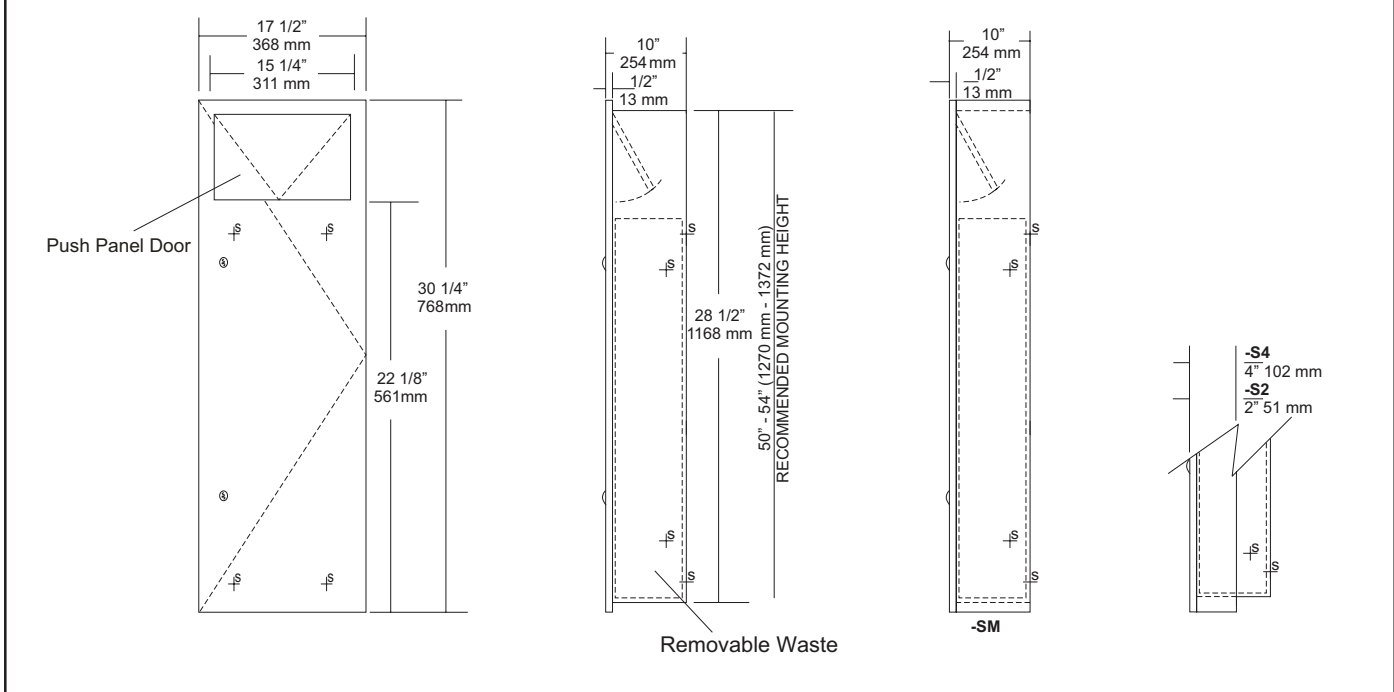

SPECIFICATIONS	INSTALLATION
----------------	--------------

Body: Fabricated of #16 gauge stainless steel with #4 satin finish on all exposed areas.

Door: Fabricated of #22 gauge, one piece stainless steel secured to body by means of a full length heavy duty stainless steel piano type hinge.

Flange: Fabricated of #22 gauge stainless steel finished to match cabinet. One piece construction without miters or welds with 1/4" returns to wall.

Removable Waste: Heavy duty pre-plated steel with large service handle for easy servicing.

Back: Fabricated of stainless steel formed for rigidity with multiple welds to cabinet.

Locks: Pin tumbler commercial quality type, keyed like all other AJW cabinets.

Collars: #22 gauge stainless steel sized and finished to match cabinet, surf mount & semi-rec.

U4454 Recessed Waste.

Overall Size: 17 1/2"W x 30 1/4"H x 10"D
362mm x 1219mm x 159mm

Wall Opening: 15 3/4"W x 28 1/2"H x 6"D
324mm x 1181mm x 152mm

U4454-S2: 2" Semi-rec. Collar with 4" (102mm) w/o

U4454-S4: 4" Semi-rec. Collar with 2" (51mm) w/o

U4454SM: Surface Mounted

Waste Capacity: 9.5 gallons (1.2 cu ft)

Coordinate installation with architect and contractor. Provide a wall opening 15 3/4"W x 28 1/2"H. Wall depth will vary will vary if collars are required. Open bottom door and remove waste from cabinet and insert in wall opening. Secure unit with proper fasteners per each application. Make sure unit is plumb. After unit has been secured, place waste back into cabinet and secure door.

NOTES

Formerly Model #: U4414M