

1 1/4" Aluminum Headrail  
 Stainless Steel Partitions

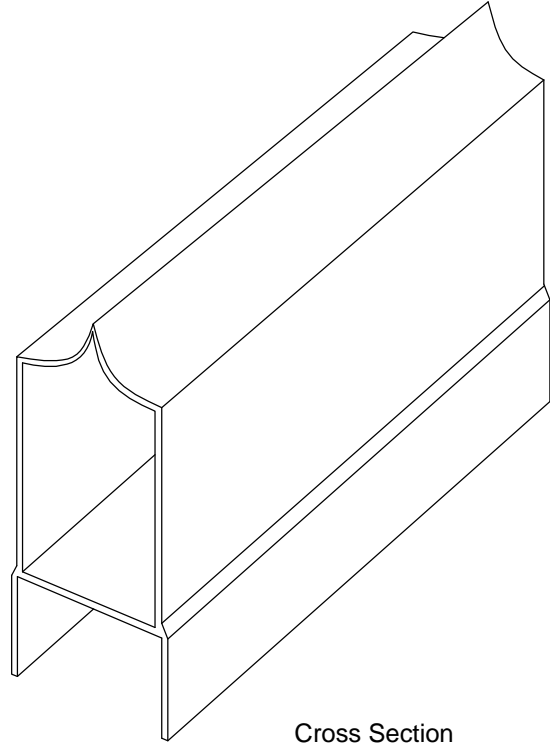
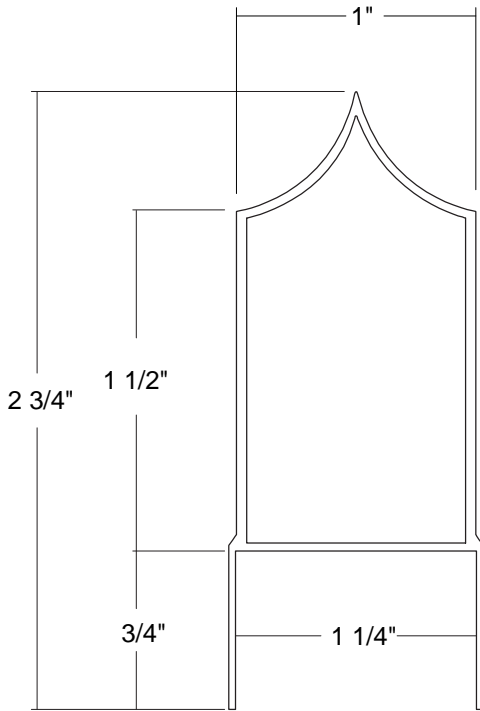

Cross Section

All headrail lengths will be oversized on drawings by 3" to compensate for field variances.

Sample Elevation

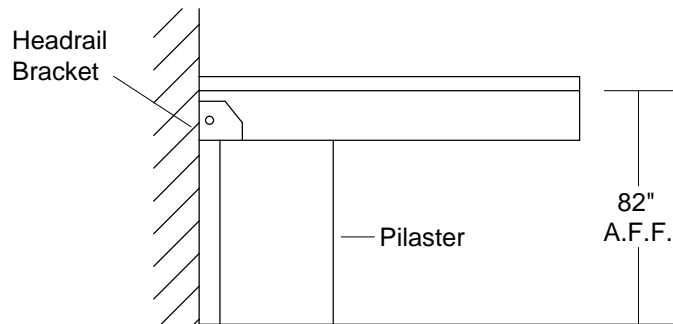

- **Material:** Clear Anodized Aluminum.
- **Application:** Overhead Bracing for floor mounted pilasters.
- **Fasteners required per component:** Headrail bracket requires (2) 1 1/2" Torx screws **or** (2) 3/4" Torx screws; (1) male/female thru-bolt pair.