

Standard Series Lockers

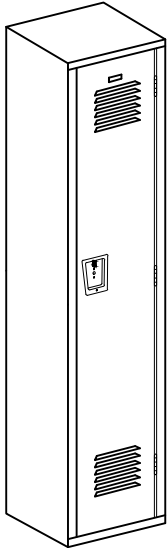

ONE TIER

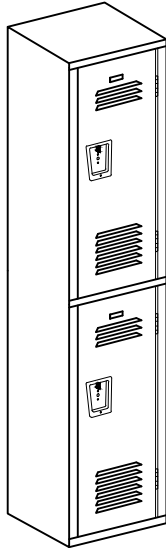

TWO TIER

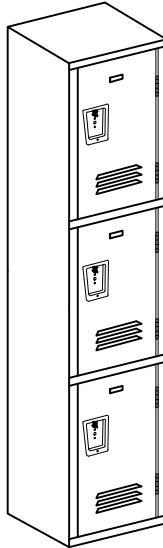

THREE TIER

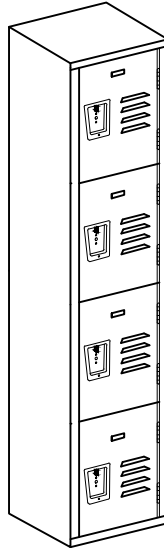

FOUR TIER

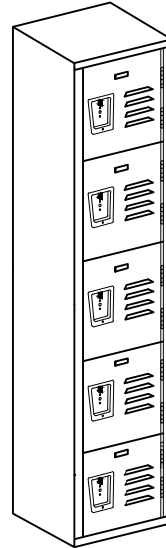

FIVE TIER

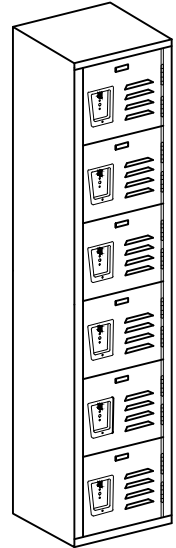

SIX TIER

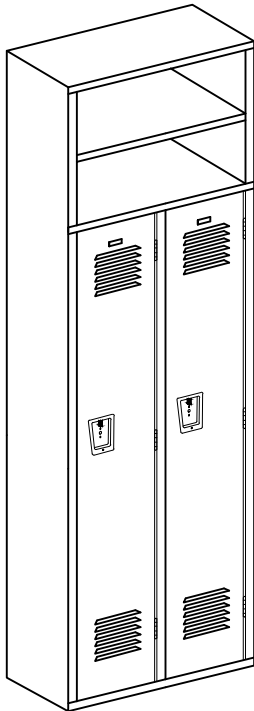

TWO PERSON

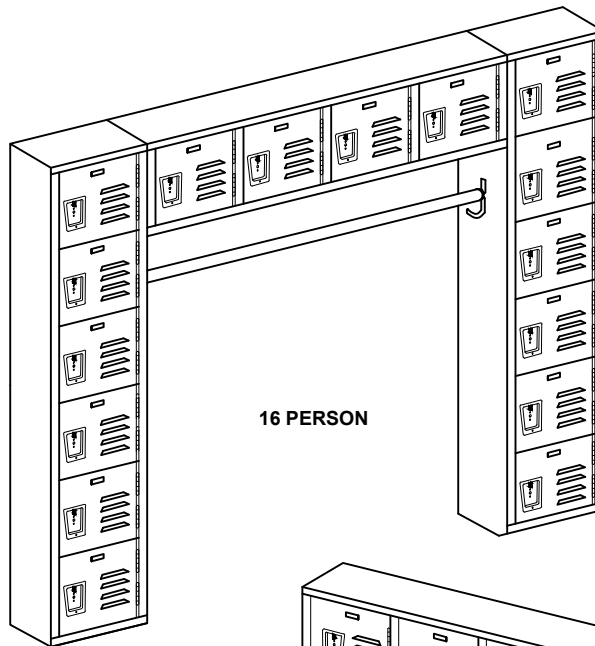

16 PERSON

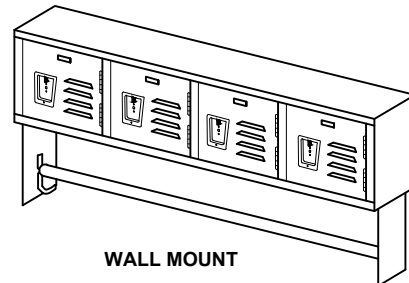

WALL MOUNT

Specifications

- **Body:** Entire unit (bottom, sides, top, back, and shelves) constructed of mild cold rolled 24 ga. commercial grade steel. Bolt spacing shall not exceed 9" on center.
- **Door:** Cold rolled 16 ga. commercial grade steel. Channel shaped on lock and hinge side with angle formations across the top and bottom. Each door shall have a polished aluminum number plate riveted to the face of the door with ½" high black numerals. Optional ventilation styles available. (14 ga. non-ventilated commercial grade steel door available).
- **Door Frame:** Cold rolled 16 ga. commercial grade steel. Channel shaped, with vertical sides having an additional flange to act as a continuous door strike.
- **Finish:** Commercial grade steel cleaned and treated with a phosphate process. Finished coat baked on, powder coated enamel.
- **Color:** Doors and exposed body parts available in colors from AJW standard color selection.
- **Hinges:** 2" five knuckle hinge pairs: 2 per door (3 pairs on doors 48" or larger), or full length 16 ga. piano hinge, riveted to frame and door.
- **Latch / Handle:** 20 ga. deep drawn stainless steel cup, able to accommodate locks. 14 ga. stainless steel lifting trigger. Padlock eye to accommodate 5/16" diameter padlock shackle. Three point latch mechanism, engaging the frame at (3) points on doors greater than 42" in height; (2) engaging points on all other doors. Rubber silencer attached to frame at each latch hook location. Single Point Latch available -- 11 ga. Steel hook with padlock hasp welded to door frame. Padlock hasp protrudes through stainless steel cup.
- **Interior:** Shelves included on all lockers 48"H and up. Two wall hooks and one ceiling hook included on all lockers. Coat rod included on all lockers 18" D.
- **Assembly:** All locker components assembled with rivets (nuts and bolts available upon request). All welded construction as a single unit available (shipped pre-assembled).

Note: Difference between knock down and welded assembly is that welded assembly is comprised of a 14 ga. door, 18 ga. back, and 16 ga. for all other parts.

Tops

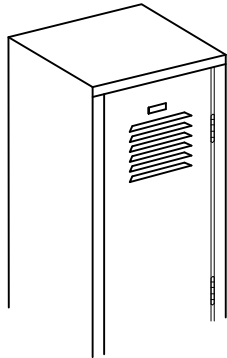

Flat Top

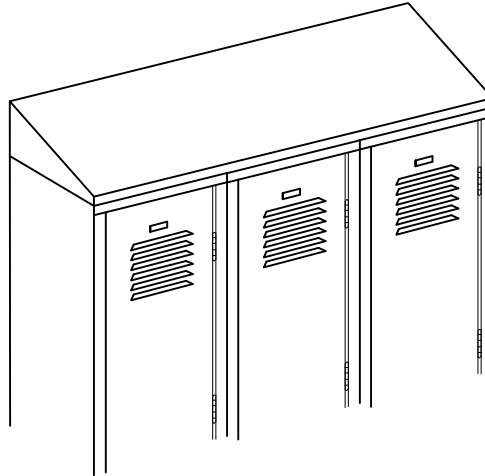

Continuous Slope

18 Ga. commercial grade steel, powder coated to match locker color. Continuous slope tops up to 72" in length. (Longer lengths connected with slip joints at splice locations). Degree of slope is 1/3 of locker depth.

Bases

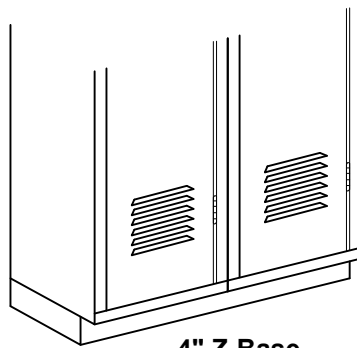

4" Z-Base

Z-Bases: 14 Ga. commercial grade steel
 6" Legs: 16 Ga. commercial grade steel
 Closed Front End: 18 Ga. commercial grade steel.
 All powder coated to match locker color.

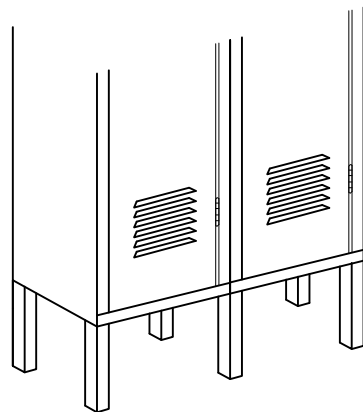

6" Legs

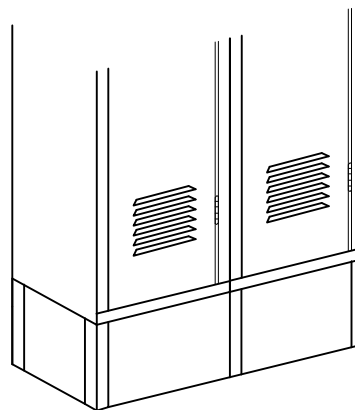

Closed Front End

Trim - (Recessed Lockers Only)

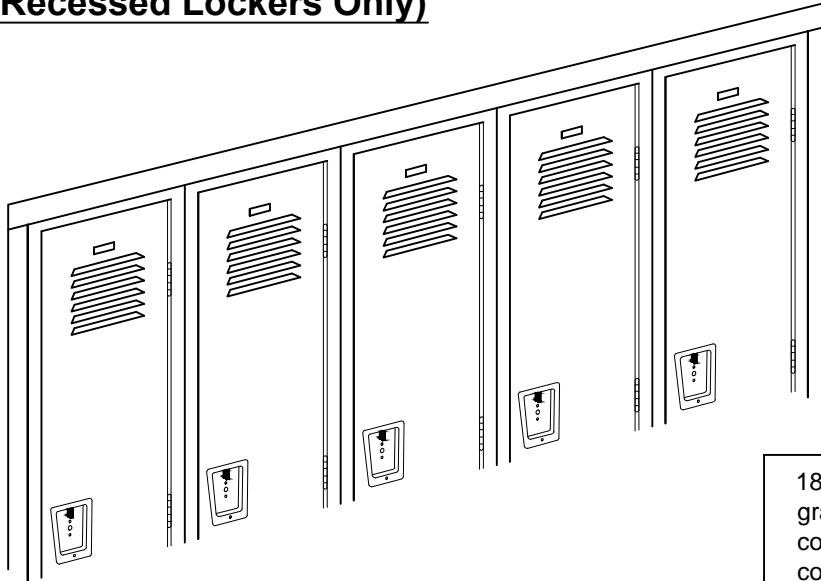

18 Ga. commercial grade steel, trim powder coated to match locker color. Trim face attached to lockers with concealed clips and endcaps.

Fillers - Vertical

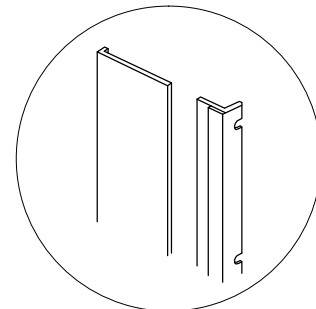
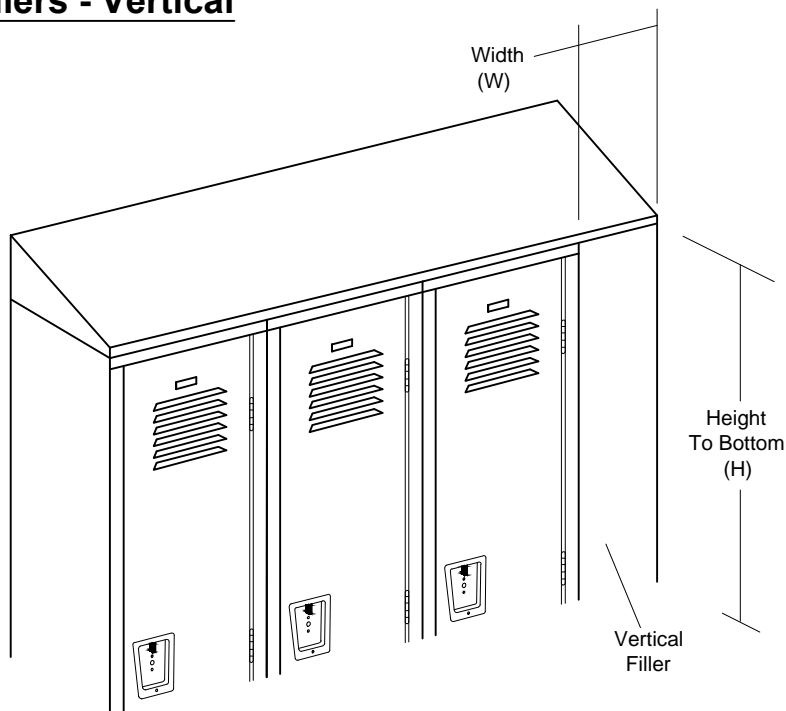

Slip Joint Detail

20 Ga. commercial grade, steel powder coated to match locker color. Fillers formed into an angle and connected with slip joints to create a smooth finish.

Ventilation Options

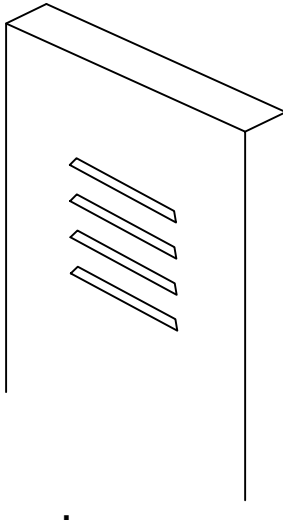

Louvers

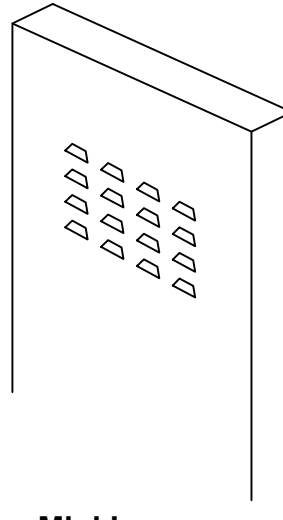

Mini Louvers

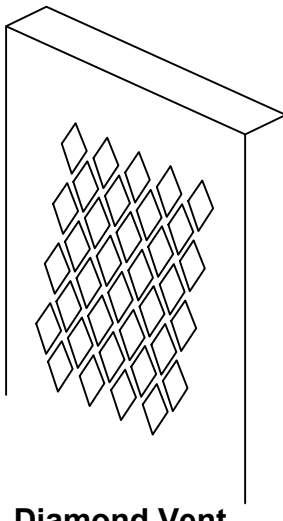

Diamond Vent

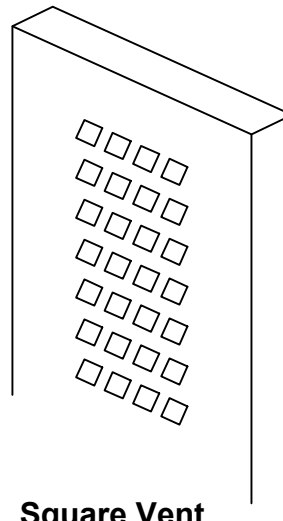

Square Vent

Single Prong Hook

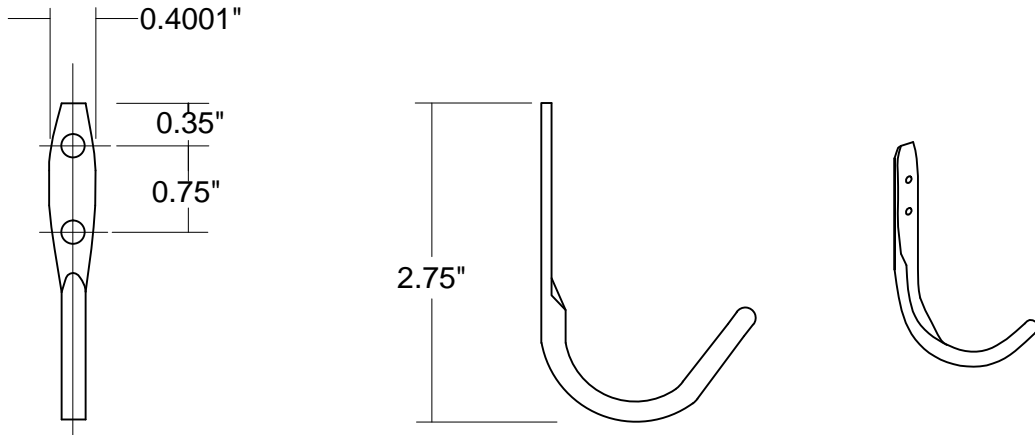

Double Prong Hook

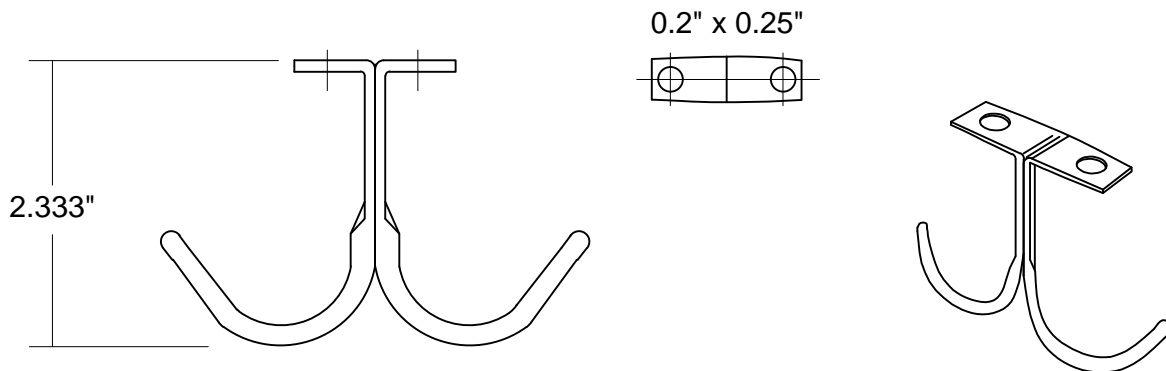

Coat Rod & Hook

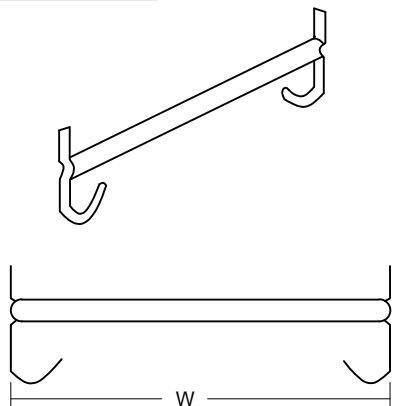

Number Plate

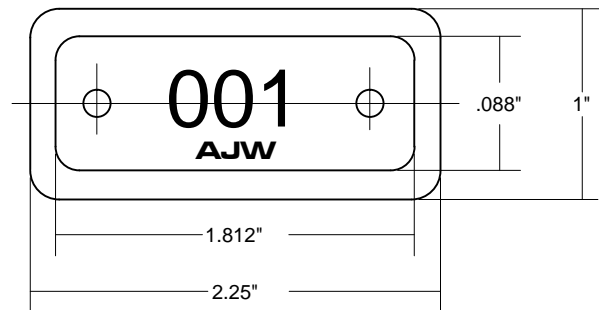

Standard Series

(W x D)	One Tier				Two Tier		Three Tier		Four Tier		Five Tier	Six Tier	2 Person
	36" H	48" H	60" H	72" H	60" H	72" H	60" H	72" H	60" H	72" H	60" H	72" H	72" H
12" x 12"	•	•	•	•	•	•	•	•	•	•	•	•	
12" x 15"	•	•	•	•	•	•	•	•	•	•	•	•	
12" x 18"	•	•	•	•	•	•	•	•	•	•	•	•	
15" x 15"			•	•	•	•	•	•			•	•	•
15" x 18"			•	•	•	•	•	•			•	•	•
18" x 18"			•	•	•	•	•	•			•	•	•

All heights are measured from flat top to flat bottom of locker. 6" legs available on all Standard Series lockers (add 6" to all heights above).

Athletic Series

(W x D)	One Tier		Two Tier		Three Tier		Four Tier		Five Tier	Six Tier
	60" H	72" H	60" H	72" H	60" H	72" H	60" H	72" H	60" H	72" H
12" x 12"	•	•	•	•	•	•	•	•	•	•
12" x 15"	•	•	•	•	•	•	•	•	•	•
12" x 18"	•	•	•	•	•	•	•	•	•	•
15" x 15"	•	•	•	•	•	•	•	•	•	•
15" x 18"	•	•	•	•	•	•	•	•	•	•
18" x 18"	•	•	•	•						
18" x 21"	•	•								
18" x 24"	•	•								
24" x 18"	•	•	•	•						
24" x 21"	•	•	•	•						
24" x 24"	•	•	•	•						

All heights are measured from flat top to flat bottom of locker. 6" legs available on all Athletic Series lockers (add 6" to all heights above).

Professional Series

(W x D)	One Tier
	72" H
24" x 18"	•
24" x 21"	•
24" x 24"	•
33" x 18"	•
33" x 21"	•
33" x 24"	•

Continuous Slope Tops

72" W (Std)	
D	H
12"	5"
15"	6"
18"	7"
21"	8"
24"	9"

Z-Bases

72" W x 4" H Front Base	
End / Splice Depth	12"
	15"
	18"
	21"
	24"
<i>Field cut front base as necessary.</i>	

Front & Closed Ends

Available W x D Combinations		
W	D	Size W x D x H
12"	12"	
15"	15"	
18"	18"	
24"	21"	
	24"	
6" H (Std)		

Trim for Recessed Lockers

L / R Side Trim	
W	H
3"	63"
	75"
Top Trim	
74" W x 3" H	
Splice	
2" W x 3" H	

Fillers

W	H
6"	60"
	66"
	72"
	78"
12"	60"
	66"
	72"
	78"