



U862

Waste Disposal & Toilet Tissue Dispenser Combination Unit

Revision 10/14

JOB #:

ITEM #:

QUANTITY:

MOUNTING	HANDING	TYPE	SIZE	OTHER

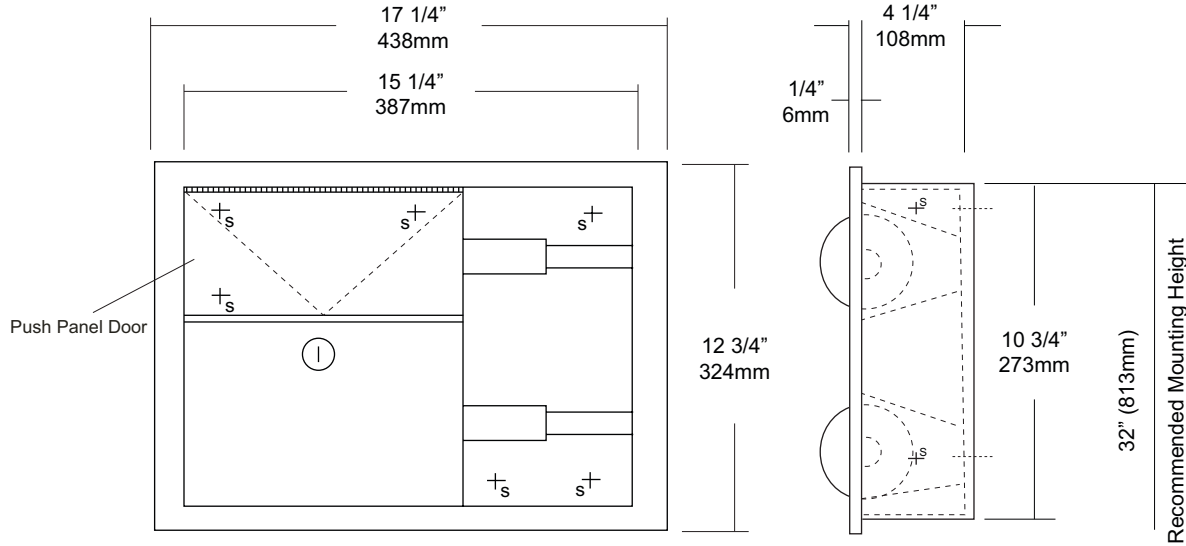

SPECIFICATIONS

- Cabinet:** Fabricated of #22 gauge stainless steel. All exposed surfaces have a #4 satin finish.
- Flange:** Fabricated of #22 gauge stainless steel one-piece drawn seamless construction. No seams or exposed miters with 1/4" returns to wall surface.
- Napkin Disposal:** Self closing push panel door is fabricated of #22 gauge stainless steel. Removable Waste is fabricated of same material with pin tumbler lock. Waste is identified with International Graphic symbol.
- Toilet Tissue Dispenser:** #22 gauge stainless steel hat adapters secure chrome plated, spring loaded rollers in place.
- U007 Theft Resistant Adapter:** Prevents spindle from being removed until roll has been depleted.
- Hinges:** All hinges are full length, heavy duty, stainless steel piano type hinges.
- Collars:** #22 ga stainless steel finished to match cabinet.
- Overall Size:** 17 1/4"W x 12 3/4"H x 4 1/4"D
438mm x 324mm x 108mm
- Wall Opening:** 15 3/4"W x 11 1/4"H x 4"D
400mm x 286mm x 102mm
- Waste Capacity:** 2 Gallons (.26 cu ft)
- Toilet Tissue:** Two standard rolls with a 5 1/4" (133mm) OD.

INSTALLATION

Provide rough wall opening at desired or specified location of 15 3/4"W x 11"H. (Depth of opening will depend on type mounting required.) Place lower unit in opening to ensure proper fit. If unit fits properly in opening, secure with proper fasteners per application. If collars are required, place collar onto the units from the back before securing to mounting area. Fill toilet tissue rolls.

Toilet Paper Dispensers: All dispensers that are to meet ADA code cannot have any type of controlled delivery. (4.16)

NOTES