



► **Culture • Focus • Results™**

At AJW, our culture is our company. With that in mind, we focus on the mechanics that support a high-performance team. Transparency, communication, discipline, and focus are cornerstones of our operational behavior.



TABLE OF CONTENTS

About AJW	1	Stainless Steel Partition Hinges	16
Solid Plastic Partitions Overview	3	Stainless Steel Partition Hardware	17
Standard Elevation - Plastic Partitions	5	Standard Elevation - Stainless Steel Partitions	19
Solid Plastic Partition Color Chart	6	Urinal Screen Details	20
Solid Plastic Partition Brackets	7	Shoe Details	20
Solid Plastic Partition Hinges	9	Heat Sinc	20
Solid Plastic Partition Hardware	11	Phenolic, Baked Enamel, Plastic Laminate Overview	21
Stainless Steel Partitions Overview	13		
Stainless Steel Partition Brackets	15		



▶ American Manufacturing

With manufacturing facilities in New York and Texas, AJW can respond with agility and precision to even the most complex initiatives. From high-style custom projects to a demanding scope of work, AJW has the team, infrastructure and experience to deliver results you can be confident in.

▶ Intelligent Sourcing

At AJW, we build partnerships that last. Many of our legacy partners have complemented our manufacturing capabilities for nearly 50 years. Consequently, we continue to leverage the depth, breadth, and strength of our supply chain to drive results and expand our distribution network globally.

▶ Better Results

High performance results are our priority. American manufacturing and intelligent sourcing allow us to leverage our in-house capabilities and our proven network of partners so that we are able to respond when it counts.



Focused on ServiceSM

▶ We Are AJW

For nearly 50 years, we have Focused on ServiceSM. As a result, our infrastructure is customer driven. We listen so that we understand your goals and objectives. We tailor our efforts and direct our action to be in concert with your needs. We measure our success by the health of our partnerships. American manufacturing, precise supply chain management and a focused culture are the fuel for better results. We are AJW.



AJW
Architectural ProductsTM

509 Temple Hill Road

HIGH-DENSITY POLYETHYLENE (HDPE) PARTITIONS

▲ AJW Solid Plastic Partitions combine elegance and durability, wherever discerning architects and builders demand the best. AJW Solid Plastic Partitions are the ideal product for heavy traffic environments prone to moisture and youthful behavior. AJW Solid Plastic Partitions resist scratches, dents, graffiti, odor, mildew, and moisture, making it one of the most low maintenance products in the industry.

Combine that with a 25 year warranty, and your AJW Solid Plastic Partitions will provide you with years of satisfied use.

With fourteen designer colors, several mounting styles, and your choice of standard or custom configurations available, our product offering enables you to create any appearance you desire – no matter how complex.

▲ SPECIFICATIONS

HDPE (High Density Polyethylene):

Integrally colored, fabricated from extruded polymer resin forming a single, one piece, solid construction sheet. Plastic is waterproof, non-absorbent, and fire rated, with a self-lubricating surface that is resistant to marks from pens, markers, and paints.

Construction:

Doors, Panels, and Pilasters are 1" thick with edges machined to rounded radius. Panels and Doors are 55 inches high, mounted 14 inches above the finished floor. Partitions are available in floor mounted-overhead braced, floor to ceiling, or ceiling hung mounting styles.

HIGH-DENSITY POLYETHYLENE (HDPE) PARTITIONS

▸ **HEADRAIL BRACED**



▸ **FLOOR TO CEILING**

▸ **CEILING HUNG**



HIGH-DENSITY POLYETHYLENE (HDPE) PARTITIONS

STANDARD ELEVATION - PLASTIC PARTITIONS

8" Aluminum Wrap Around Hinge - Aluminum Stirrup Brackets
 Floor Mounted Overhead Braced

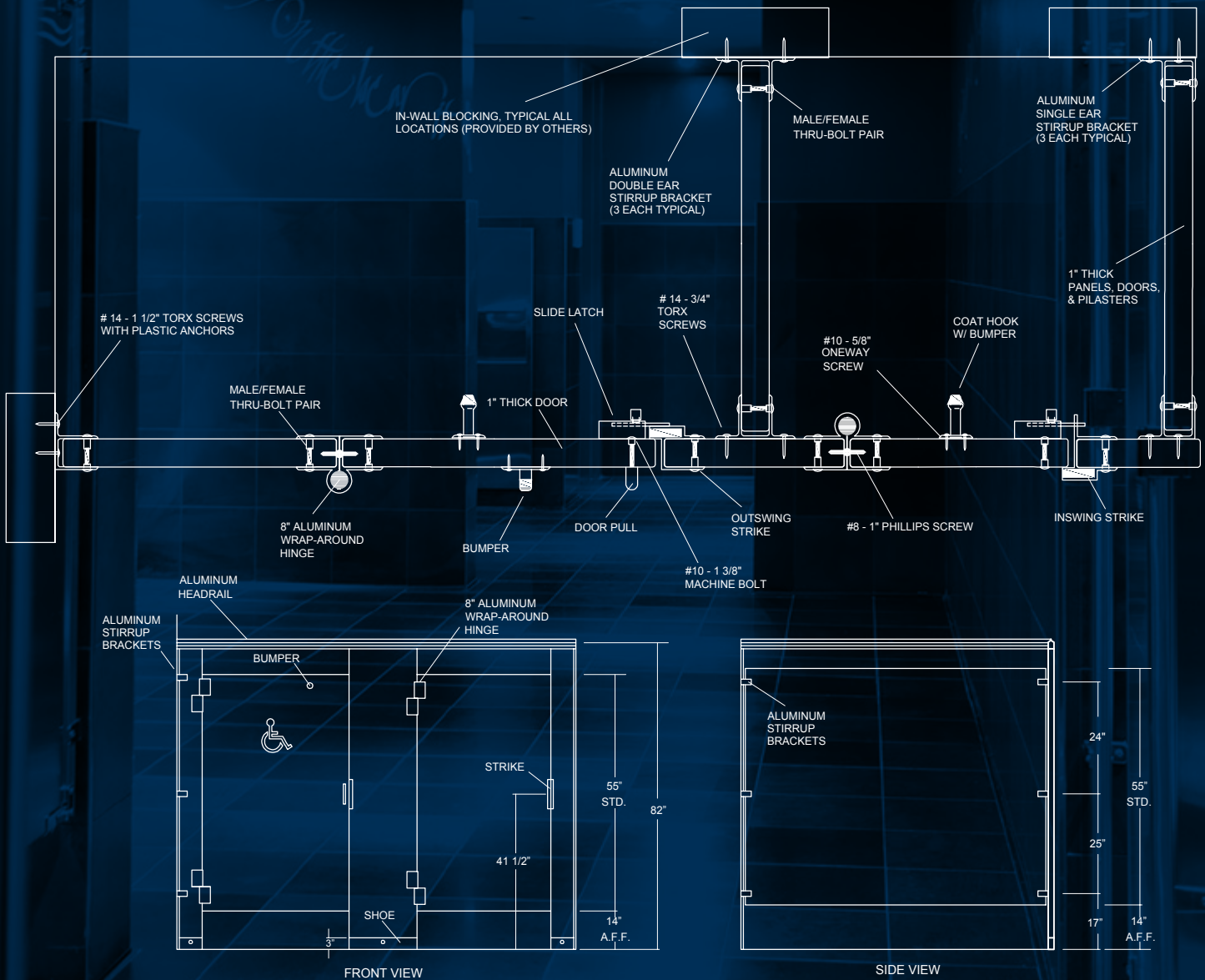

HIGH-DENSITY POLYETHYLENE (HDPE) PARTITIONS

SOLID PLASTIC COLOR CHART



Moonlight Granite



Beige



Sage Green



Grey



Linen



Mocha



Forest Green



Slate



Sandstorm



Parchment

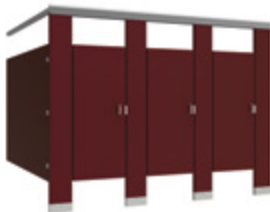

Burgundy



Black Matrix



Royal Blue



Black

Note:
Color charts are printed approximations - actual colors may vary. Please contact AJW to request a sample.

HIGH-DENSITY POLYETHYLENE (HDPE) PARTITIONS

BRACKETS

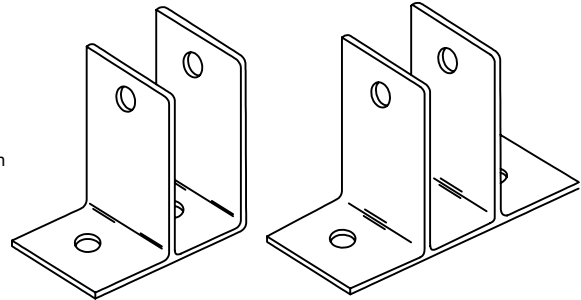
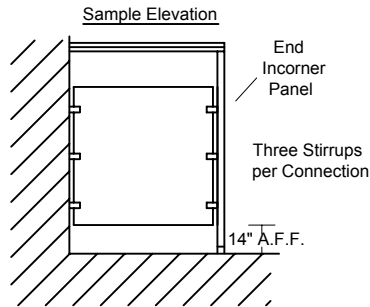

Aluminum Stirrups

- **Material:** 1/8" Thick, Clear Anodized Aluminum.
- **Application:** Wall-to-panel connections, panel-to-pilaster connections. Three per connection.
- **Fasteners required per component:** (2) 1 1/2" Torx screws or (2) 3/4" Torx screws;
(1) male/female thru-bolt pair.

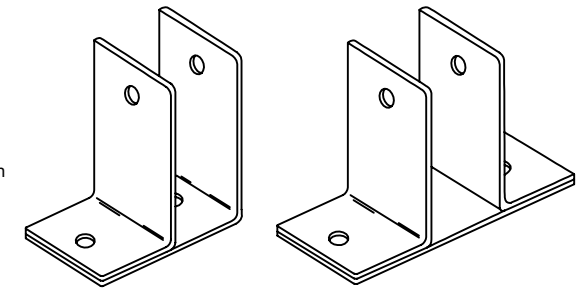
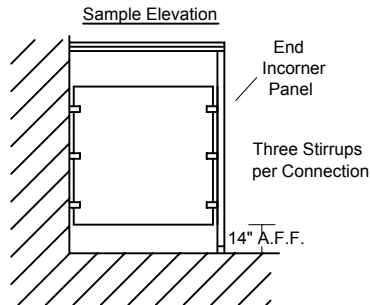
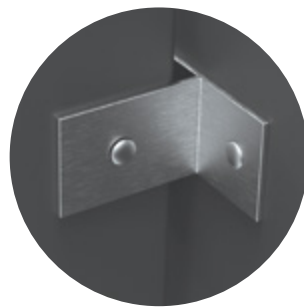

Stainless Steel Stirrups

- **Material:** 14 ga. Stainless Steel, #4 Satin Finish.
- **Application:** Wall-to-panel connections, panel-to-pilaster connections. Three per connection.
- **Fasteners required per component:** (2) 1 1/2" Torx screws or (2) 3/4" Torx screws;
(1) male/female thru-bolt pair.

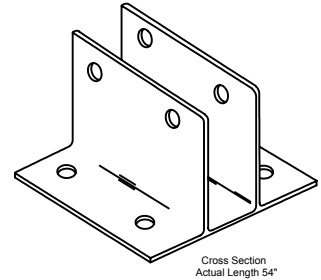
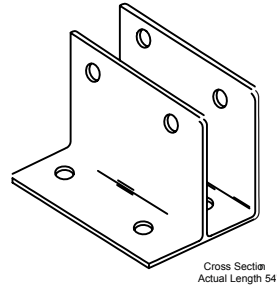
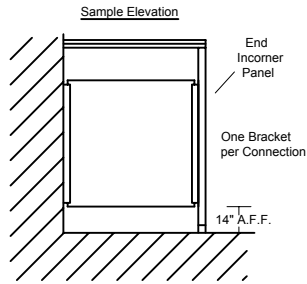

Aluminum Continuous

- **Material:** 1/8" Thick, Clear Anodized Aluminum.
- **Application:** Wall-to-panel connections, panel-to-pilaster connections.
- **Fasteners required per component:** (10) 1 1/2" Torx screws or (10) 3/4" Torx screws;
(5) male/female thru-bolt pairs.

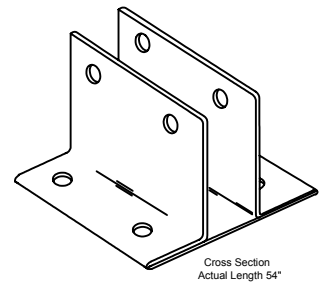
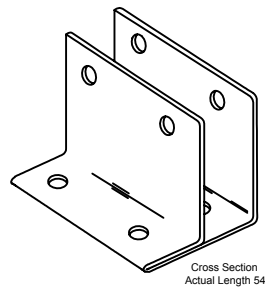
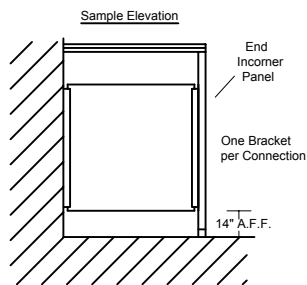

Stainless Steel Continuous

- **Material:** 18 ga. Stainless Steel, #4 Satin Finish.
- **Application:** Wall-to-panel connections, panel-to-pilaster connections.
- **Fasteners required per component:** (10) 1 1/2" Torx screws or (10) 3/4" Torx screws;
(5) male/female thru-bolt pairs.

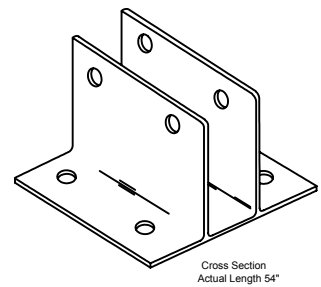
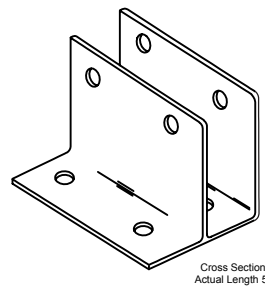
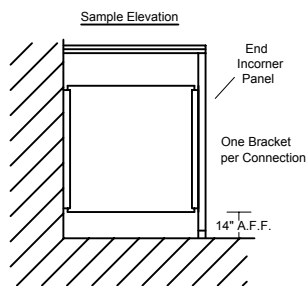

Plastic Continuous

- **Material:** PVC Plastic.
- **Application:** Wall-to-panel connections, panel-to-pilaster connections.
- **Fasteners required per component:** (10) 1 1/2" Torx screws or (10) 3/4" Torx screws;
(5) male/female thru-bolt pairs.

HIGH-DENSITY POLYETHYLENE (HDPE) PARTITIONS

HINGES

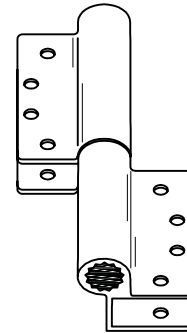
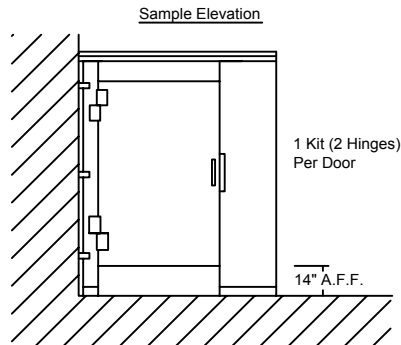

8" Aluminum Wrap Around

- **Material:** 1/8" Thick, Clear Anodized Aluminum. Black Nylon insert with Stainless Steel pin.
- **Application:** Door-to-pilaster connections.
- **Fasteners required per component:** (2) #8 x 1" Phillips Flat Screws; (8) male/female thru-bolt pairs.

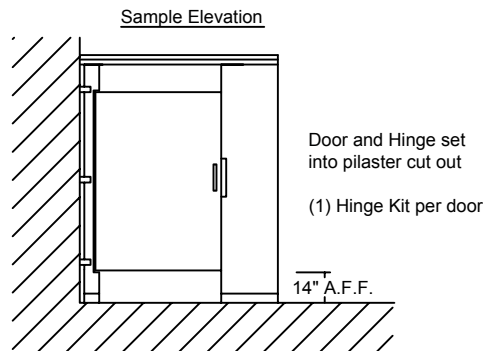

TOP ASSEMBLY



BOTTOM ASSEMBLY



Integral Hinge Kit

- **Material:** Black nylon. Stainless Steel pins/screws.
- **Application:** Door-to-pilaster connections.
- **Fasteners required per component:** N/A.

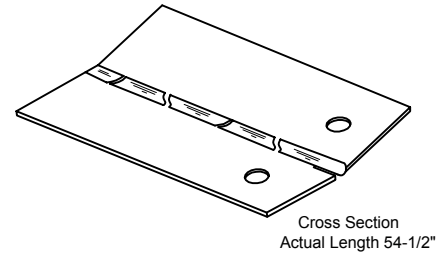
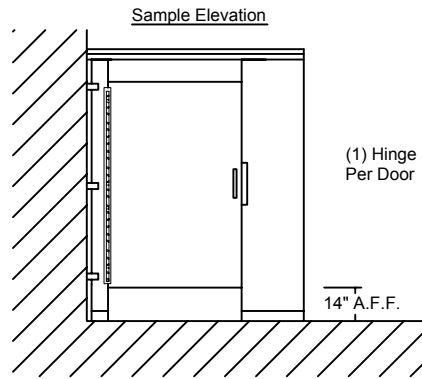

Continuous Stainless Steel Helix

- **Material:** 14 ga. Stainless Steel, #4 Satin Finish.
- **Application:** Door-to-pilaster connections.
- **Fasteners required per component:** (10) male/female thru-bolt pairs.

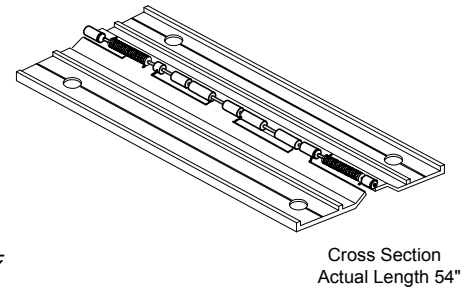
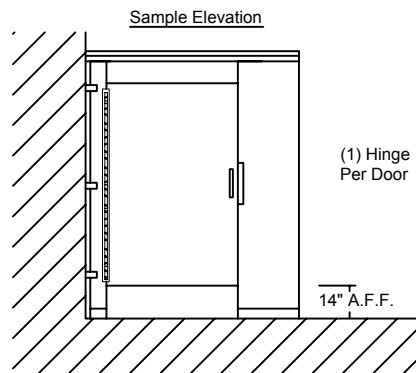

Continuous Aluminum

- **Material:** Extruded Satin Finish Aluminum. Stainless Steel pivot pin and wire springs.
- **Application:** Door-to-pilaster connections.
- **Fasteners required per component:** (10) male/female thru-bolt pairs.

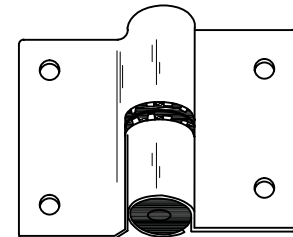
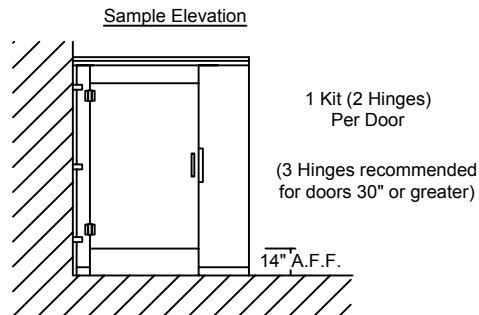

Surface Mounted Stainless Steel

- **Material:** 11 ga. Stainless Steel, #4 Satin Finish.
- **Application:** Door-to-pilaster connections.
- **Fasteners required per component:** (4) male/female thru-bolt pairs.

HIGH-DENSITY POLYETHELENE (HDPE) PARTITIONS

DOOR HARDWARE DETAILS

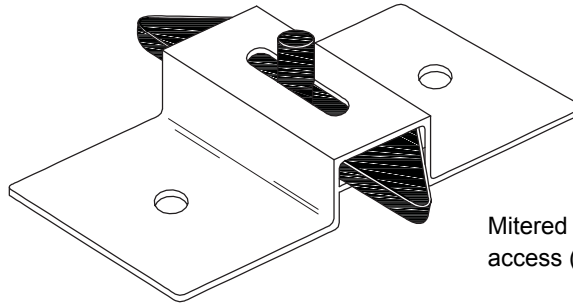

Mitered Latch allows for emergency access (1" Slide Distance)

Aluminum Slide Latch

- **Material:** 1/8" Thick, Clear Anodized Aluminum (body), Black painted Aluminum (latch).
- **Application:** Secure each compartment when occupied.
- **Fasteners required per component:** (2) 1 3/8" male machine bolts (connects to door pull on opposite side of the door), or (2) male/female thru-bolts (for surface mounting with no door pull).



Inswing



Outswing

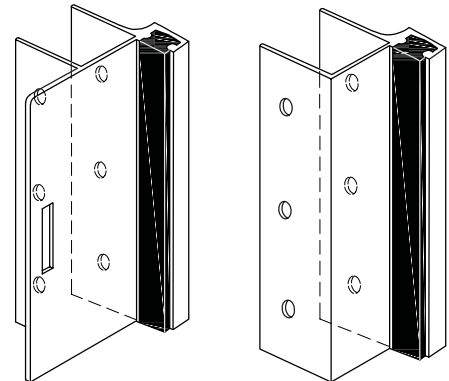

Aluminum Strikes

- **Material:** 1/8" Thick, Clear Anodized Aluminum, Black Rubber.
- **Application:** Allows door to be secured with slide latch.
- **Fasteners required per component:** (3) male/female thru-bolt pairs.
- *Available in 54" continuous length for "no sight" option.*

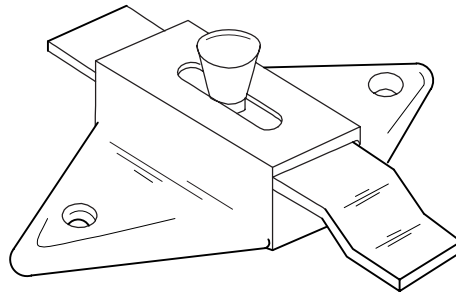

Offset Latch
allows for emergency access
(15/16" Slide Distance)

Stainless Steel Slide Latch

- **Material:** Cast Stainless Steel.
- **Application:** Secure each compartment when occupied.
- **Fasteners required per component:** (2) male/female thru-bolt (for surface mounting with no door pull).



Inswing



Outswing

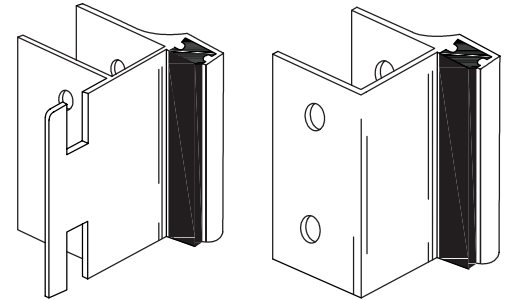

Stainless Steel Strikes

- **Material:** 1/8" Thick, Cast Stainless Steel, Black Rubber.
- **Application:** Allows door to be secured with slide latch.
- **Fasteners required per component:** (2) male/female thru-bolt pairs.



Sample Elevation

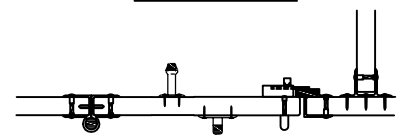

Bumper

- **Material:** Chrome Plated Zamac.
- **Application:** (1) per outswinging handicap door.
- **Fasteners required per component:** (2) 5/8" one way screws.

Hook & Bumper

- **Material:** Chrome on Brass.
- **Application:** (1) per door.
- **Fasteners required per component:** (2) 5/8" one way screws.

STAINLESS STEEL PARTITIONS

▶ AJW Stainless Steel Partitions are fabricated with precision at our manufacturing facility in the Hudson Valley region of New York State. AJW's stainless steel partitions will complement the design of your restroom by adding elements of sophistication, strength and durability. AJW offers several mounting styles and your choice of standard or custom configurations.

Our product offering enables you to create any appearance you desire – no matter how complex.

- 5 Year Warranty
- Traditional or high-style hardware available
- All welded corners
- Corrosion resistant

▶ FINISH OPTIONS

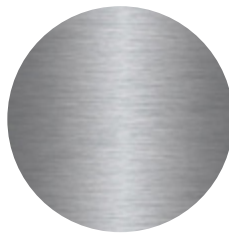

Satin Finish

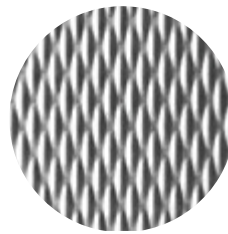

5WL Textured Finish

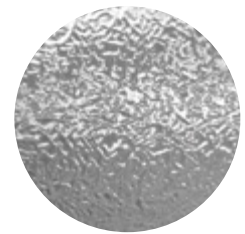

Leather Grain Finish

▶ SPECIFICATIONS

Stainless Steel:

Type 304 stainless steel, complying with ASTM A167.

Construction:

Doors and Panels are 1" thick (Pilasters are 1 1/4" thick), and constructed of two face sheets of 20 gauge stainless steel bonded under pressure to honeycomb core. Formed sheets are welded together at intervals around the perimeter. Perimeter edges are sealed

with a continuous 20 gauge interlocking stainless steel molding. Panels and Doors are 58 inches high, mounted 12 inches above the finished floor. Partitions are available in floor mounted-overhead braced, floor to ceiling, floor mounted, or ceiling hung mounting styles.

STAINLESS STEEL PARTITIONS

▶ **FLOOR MOUNTED
OVERHEAD BRACED**



▶ **FLOOR
TO CEILING**

▶ **CEILING
MOUNTED**



▶ **FLOOR
MOUNTED**



STAINLESS STEEL PARTITIONS

BRACKETS

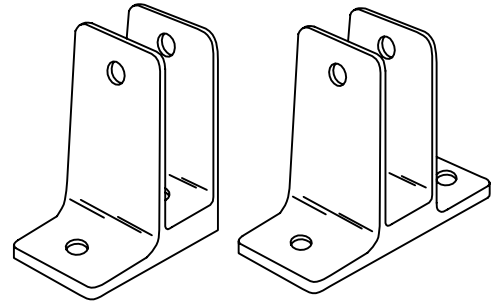
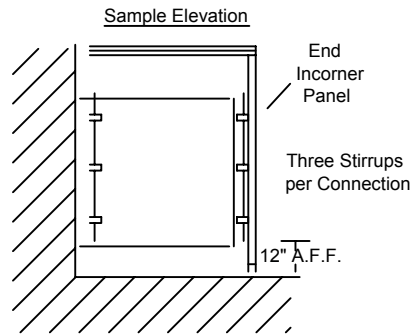

Chrome Plated Stirrups

- **Material:** Chrome Plated Zamac.
- **Application:** 1" brackets for wall-to-panel connections, and panel-to-pilaster connections.
1 1/4" brackets for wall-to-pilaster connections. Three per connection.
- **Fasteners required per component:** (2) 1 1/2" Torx screws or (2) 3/4" Torx screws;
(1) male/female thru-bolt pair.

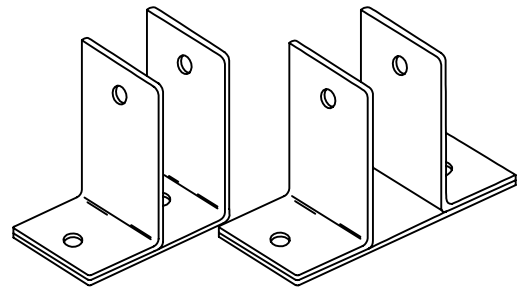
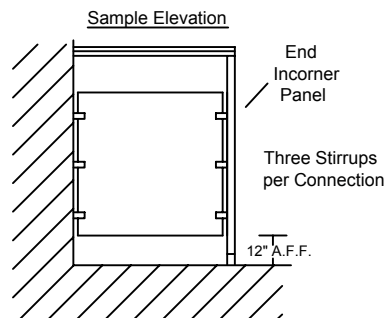

Stainless Steel Stirrup

- **Material:** 14 ga. Stainless Steel, #4 Satin Finish.
- **Application:** 1" brackets for wall-to-panel connections, and panel-to-pilaster connections.
1 1/4" brackets for wall-to-pilaster connections. Three per connection.
- **Fasteners required per component:** (2) 1 1/2" Torx screws or (2) 3/4" Torx screws;
(1) male/female thru-bolt pair.

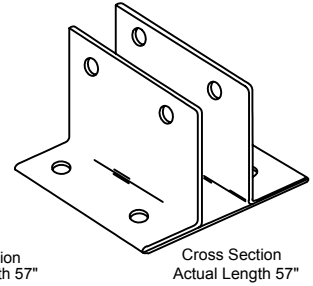
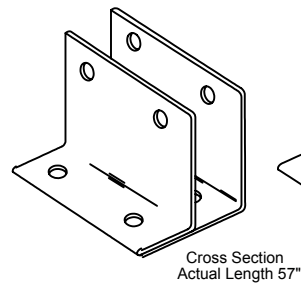
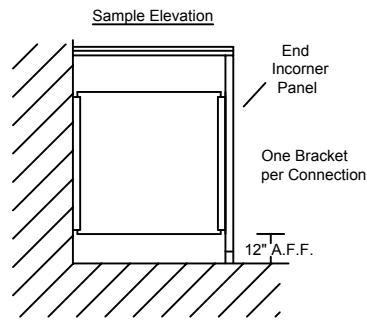

Continuous Stainless Steel

- **Material:** 18 ga. Stainless Steel, #4 Satin Finish.
- **Application:** Wall-to-panel connections, panel-to-pilaster connections.
1 1/4" brackets for wall-to-pilaster connections.
- **Fasteners required per component:** (10) 1 1/2" Torx screws or (10) 3/4" Torx screws;
(5) male/female thru-bolt pairs.

HINGE DETAILS

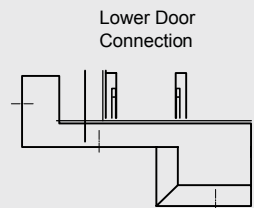
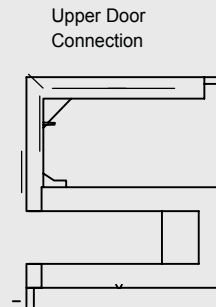
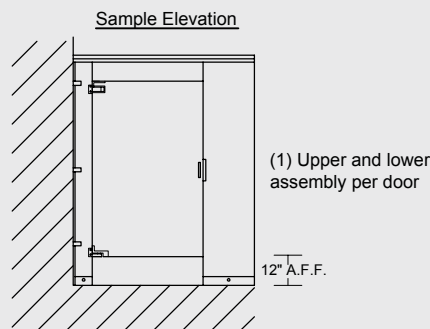

Chrome Plated Cutout Inset Gravity

- **Material:** Chrome Plated Zamac.
- **Application:** Door-to-pilaster connections.
- **Fasteners required per component:** (4) male/female thru-bolt pairs.

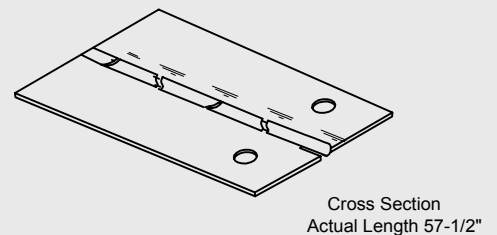
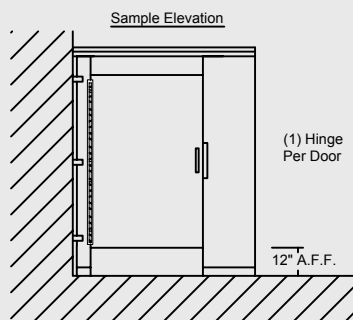
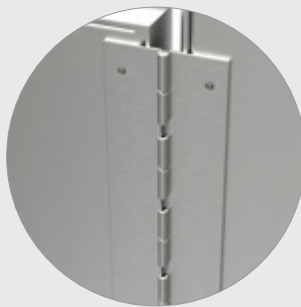

Continuous Stainless Steel Helix

- **Material:** 14 ga. Stainless Steel, #4 Satin Finish.
- **Application:** Door-to-pilaster connections.
- **Fasteners required per component:** (10) male/female thru-bolt pairs.

STAINLESS STEEL PARTITIONS

DOOR HARDWARE DETAILS

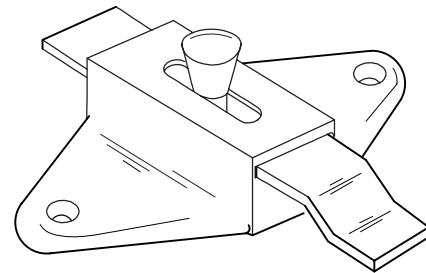
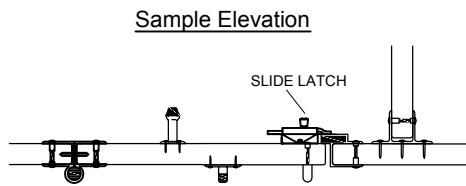

Offset Latch
allows for emergency access
(15/16" Slide Distance)

Chrome Plated Slide Latch

- **Material:** Chrome Plated Zamac.
- **Application:** Secure each compartment when occupied.
- **Fasteners required per component:** (2) male/female thru-bolt (for surface mounting with no door pull).



Inswing



Outswing

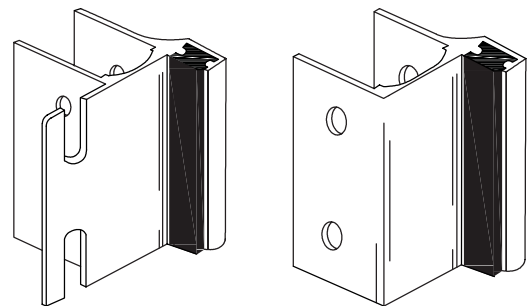

Chrome Plated Strikes

- **Material:** 1/8" Thick, Chrome Plated Zamac, Black Rubber.
- **Application:** Allows door to be secured with slide latch.
- **Fasteners required per component:** (2) male/female thru-bolt pairs.

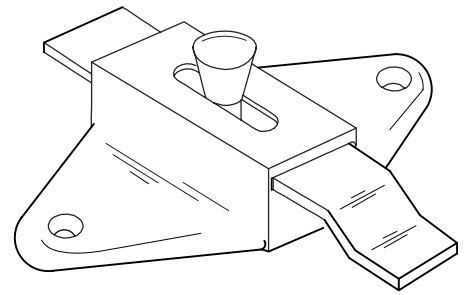
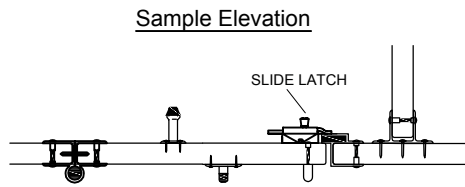

Offset Latch
allows for emergency access
(15/16" Slide Distance)

Stainless Steel Slide Latch

- **Material:** Cast Stainless Steel.
- **Application:** Secure each compartment when occupied.
- **Fasteners required per component:** (2) male/female thru-bolt (for surface mounting with no door pull).



Inswing



Outswing

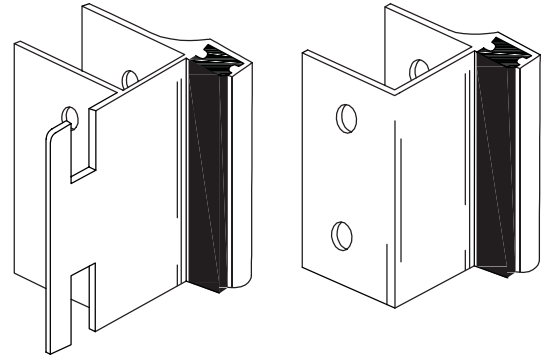

Stainless Steel Strikes

- **Material:** 1/8" Thick, Cast Stainless Steel, Black Rubber.
- **Application:** Allows door to be secured with slide latch.
- **Fasteners required per component:** (2) male/female thru-bolt pairs.

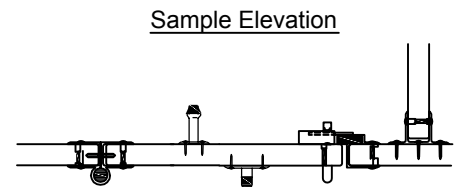

Bumper

- **Material:** Chrome Plated Zamac.
- **Application:** (1) per outswinging handicap door.
- **Fasteners required per component:** (2) 5/8" one way screws.

Hook & Bumper

- **Material:** Chrome on Brass.
- **Application:** (1) per door.
- **Fasteners required per component:** (2) 5/8" one way screws.

STAINLESS STEEL PARTITIONS

STANDARD ELEVATION - STAINLESS STEEL PARTITIONS

Cutout Inset Gravity Hinge - Chrome Plated Stirrup Brackets
 Floor Mounted Overhead Braced

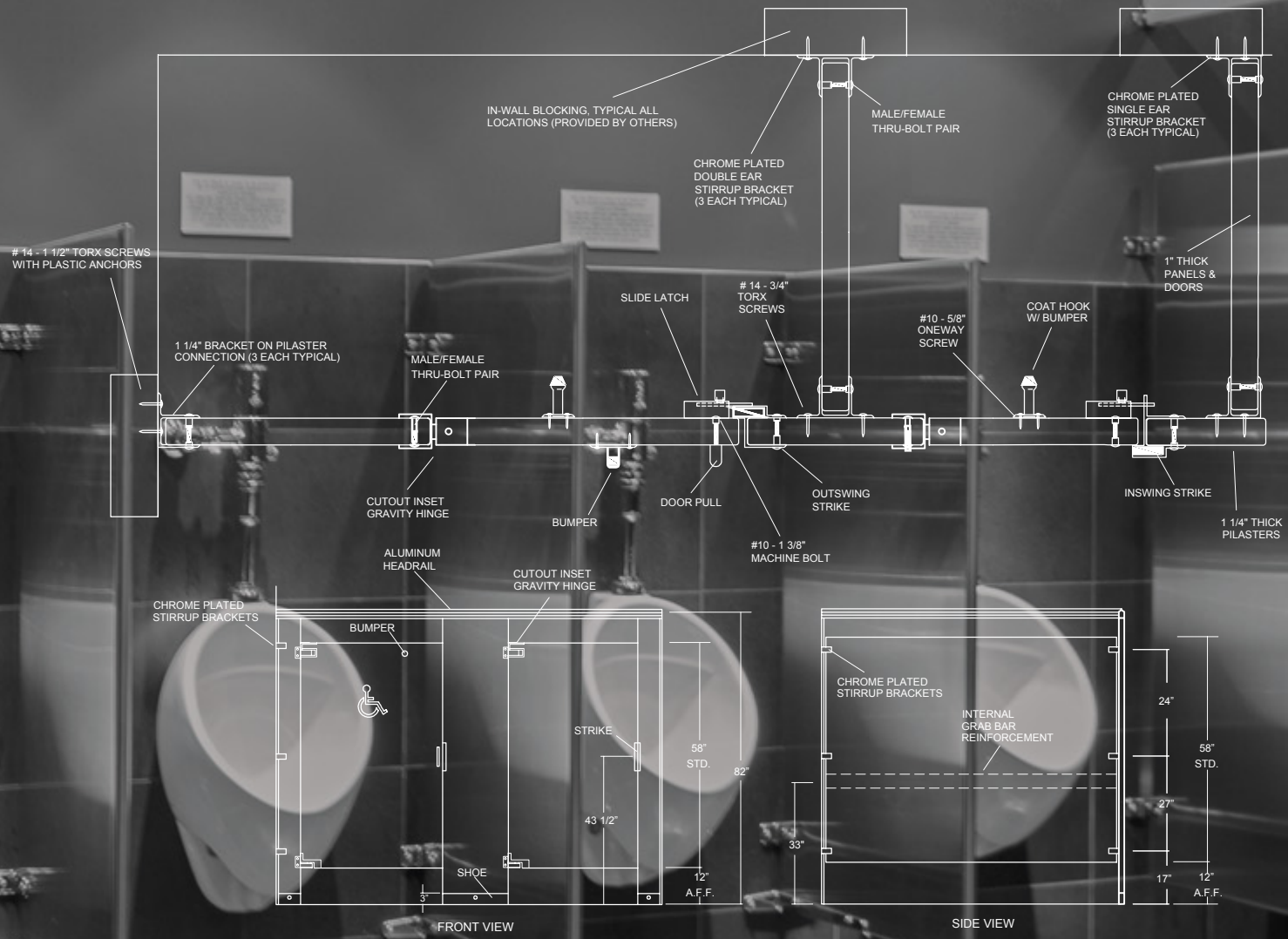

URINAL SCREENS

URINAL SCREEN DETAILS

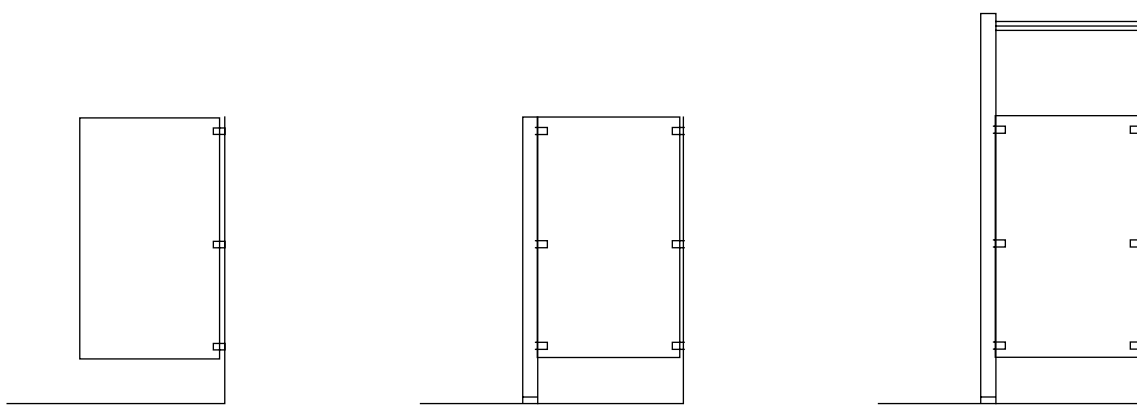

General

- Three basic mounting styles - Wall Hung, Floor Supported, Overhead Braced.
- Standard sizes: 18" X 42", 18" X 48", 24" X 42", 24" X 48"
- Custom sizes available.
- HDPE urinal screens mounted 14" AFF, stainless steel urinal screens mounted 12" AFF.

SHOE DETAILS



Plastic Shoe



Stainless Steel Shoe

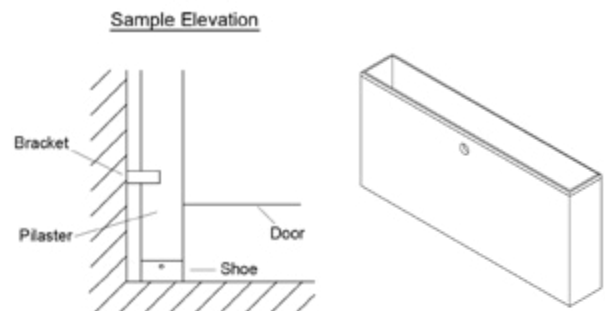

- **Material:** 20 ga. Stainless Steel, # 4 Satin Finish, or one piece molded HDPE.
- **Application:** Secure pilaster to finished floor.
- **Fasteners required per component:** (2) 1 1/2" Torx screws, (1) male/female thru-bolt pair.

HEAT SINC

Optional aluminum strip applied to underside of all doors and panels (HDPE partitions only).

ADDITIONAL PARTITION MATERIALS

PHENOLIC, BAKED ENAMEL, PLASTIC LAMINATE PARTITIONS OVERVIEW

Material	Construction	Thickness	Warranty
Phenolic (Black Core)	Resin-impregnated kraft paper core with laminate surface.	3/4" thick doors and pilasters. 1/2" panels.	10 Years
Plastic Laminate	Particleboard core with laminate surface.	1" thick doors and panels. 1 1/4" thick pilasters.	2 Years
Baked Enamel	Two galvanized steel sheets, bonded under pressure to honeycomb core, with welded channel trim. Baked on powder coated finish.	1" thick doors and panels. 1 1/4" thick pilasters.	3 Years

All four mounting styles available - Floor Mounted Overhead Braced, Floor Mounted, Floor-to-Ceiling, Ceiling Hung. Multiple hardware and color options available. Contact AJW for additional details.

ADDITIONAL PARTITION MATERIALS

OVERVIEW

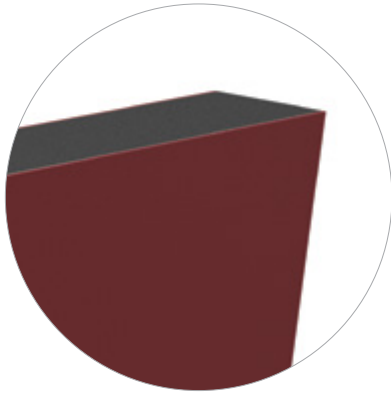

Phenolic Black Core

AJW Phenolic Partitions are the ideal product for high traffic environments. This type of partition is fabricated with a resin-impregnated kraft paper core that will not delaminate. This method of construction enables AJW Phenolic Partitions to be largely resistant to water and bacteria. AJW Phenolic Partitions are manufactured with a decorative face sheet on both sides. With flexible color and pattern options available, AJW Phenolic Partitions can accommodate your design requirements.

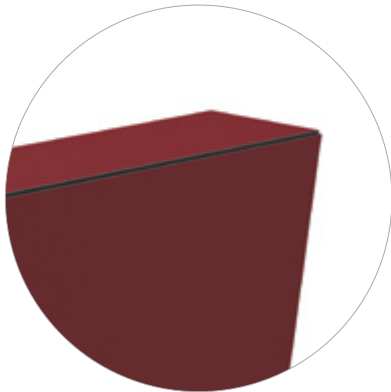

Plastic Laminate

AJW Plastic Laminate Partitions suit projects that require high-design and low maintenance. Our plastic laminate partitions are constructed with highly durable plastic laminate face sheets that are bonded under high pressure to a solid particleboard core. AJW Plastic Laminate Partitions are available in an endless array of patterns and colors, complementing the design of many projects by allowing you to match your other interior design elements.



Baked Enamel

AJW Baked Enamel Partitions are the perfect choice when your design requires a flexible and stylish product. Our baked enamel partitions are fabricated with commercial grade galvanized steel, bonded under pressure to a resin impregnated honeycomb core. As a result, AJW Baked Enamel Partitions are durable and elegant. AJW Baked Enamel Partitions are finished with electrostatically applied paint that helps to guard the steel from corrosion and provides an attractive finish. With numerous color options available, your AJW Baked Enamel Partitions will assist you in achieving the designer look you are after.



- Mirrors & Shelves
- Grab Bars
- Hand Dryers
- Towel Dispensers
- Custom Accessories

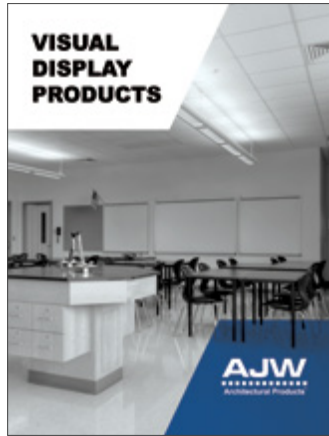

- Markerboards
- Tackboards
- Sliders
- Combination Boards
- Glass Markerboards



- Standard Series Lockers
- Professional Series Lockers
- Athletic Series Lockers
- TA-50 Series Lockers
- Benches



Volume 1

509 Temple Hill Road
New Windsor, NY 12553-5532

Phone (845) 562-3332

Fax (845) 562-3391

www.ajw.com